

SONY®

5-024-552-14(1)

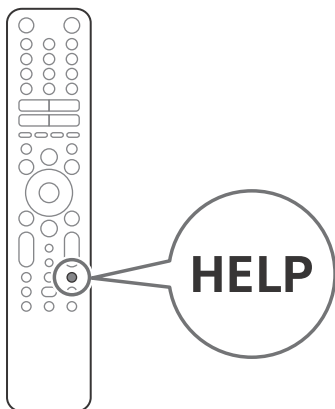

Television



Reference Guide	GB
Guide de référence	FR
Guía de referencia	ES
Referentiegids	NL
Referenzanleitung	DE
Guia de referència	PT
Guida di riferimento	IT
Referensmaterial	SE
Referencevejledning	DK
Viiteopas	FI
Referanseveiledning	NO
Przewodnik	PL
Referenční příručka	CZ
Referenčná príručka	SK
Felhasználói útmutató	HU
Ghid de referință	RO
Информация за продукта	BG
Οδηγός αναφοράς	GR
Başvuru Kılavuzu	TR
Справочник	RU
Довідковий посібник	UA

BRAVIA

XR-83A9xJ / 65A9xJ / 55A9xJ

About Manuals

This TV comes with the following manuals. Please retain the manuals for future reference.

Setup Guide

- TV installation and setup.

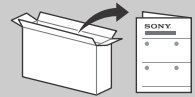

Reference Guide (this manual) / Safety Documentation

- Safety information, remote control, troubleshooting, wall-mount installation, specification, etc.



Help Guide (On screen Manual)

- Settings, functions, Internet connection, troubleshooting, etc.
- To open it, press the **HELP** button on the remote control and select Help Guide.



- You can refer to the Help Guide with your smartphone.



https://rd1.sony.net/help/tv/iaep1/h_aep/

Setting menus are subject to change without notice.

IMPORTANT - Read the End User Software Licence Agreement before using your Sony product. Using your product indicates your acceptance of the End User Software Licence Agreement. The software licence agreement between you and Sony is available online at Sony website (<https://www.sony.net/tv-software-licenses/>) or on your product screen. Press  (Quick Settings) on the remote control and select [Settings] → [System] → [About] → [Legal information] → [Notices and licences].

For this radio equipment, the following restrictions on putting into service or of requirements for authorization of use apply in AT, BE, HR, CY, CZ, DK, EE, FI, FR, DE, EL, HU, IE, IT, LV, LT, LU, MT, NL, PL, PT, SK, SI, ES, SE, UK, UK (NI), IS, LI, NO, CH, BG, RO, TR, AL, BA, MK, MD, RS, ME, Kosovo :
5150 - 5350 MHz band is restricted to indoor operations only.

Safety Information

Installation/Set-up

Install and use the TV set in accordance with the instructions below in order to avoid any risk of fire, electric shock or damage and/or injuries.

Installation

- The TV set should be installed near an easily accessible mains socket.
- Place the TV set on a stable, level surface to prevent it from falling over and causing personal injury or property damage.
- Install the TV where it cannot be pulled, pushed, or knocked over.
- Install the TV so that the TV's Table-Top Stand does not protrude out from the TV stand (not supplied). If the Table-Top Stand protrudes out from the TV stand, it may cause TV set to topple over, fall down, and cause personal injury or damage to the TV.

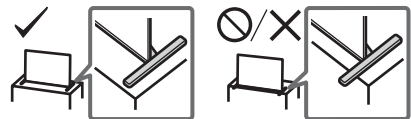

Transporting

- Before transporting the TV set, disconnect all cables.
- Before transporting the TV set, remove the stand cover and terminal covers.
- Two or more people (three or more people for XR-83A9xJ) are needed to transport a large TV set.

Note

- Before operating the TV, please read the "Safety Information".
- Read the supplied safety documentation for additional safety information.
- Images and illustrations used in the Setup Guide and this manual are for reference only and may differ from the actual product.
- The "x"/"xx" that appears in the model name corresponds to a numeric digit, related to design, colour or TV system.

Location of the identification label

Labels for the TV Model No., Production Date (year/month) and Power Supply rating are located on the rear of the TV or package. They can be found by removing the terminal cover.

IMPORTANT NOTICE

Notice for Radio Equipment

Hereby, Sony Corporation declares that the radio equipment types XR-83A90J, XR-65A90J, XR-55A90J are in compliance with Directive 2014/53/EU. The full text of the EU declaration of conformity is available at the following internet address: <https://compliance.sony.eu>

Hereby, Sony Corporation declares that the radio equipment types XR-83A90J, XR-65A90J, XR-55A90J are in compliance with the UK relevant statutory requirements. The full text of the declaration of conformity is available at the following internet address: <https://compliance.sony.co.uk>

- When transporting the TV set by hand, hold it as shown below. Do not put stress on the panel and the frame around the screen.

XR-83A9xJ

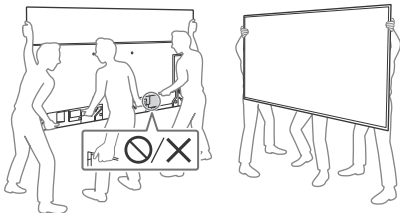

XR-65A9xJ / 55A9xJ

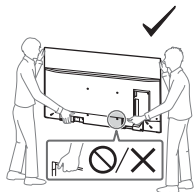

XR-83A9xJ / 65A9xJ / 55A9xJ

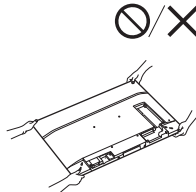

- When handling or mounting the TV set, do not lay down the TV.

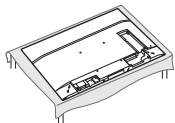

- When transporting the TV set, do not subject it to jolts or excessive vibration.
- When transporting the TV set for repairs or when moving, pack it using the original carton and packing material.

Topple prevention

XR-83A9xJ

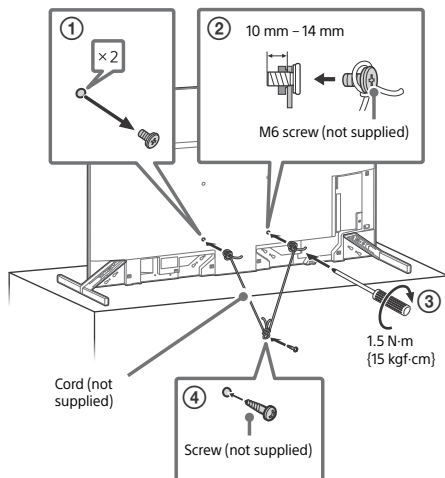

XR-65A9xJ / 55A9xJ

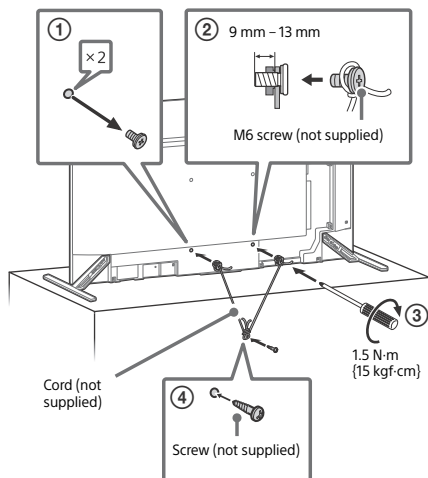

Protecting the TV Screen (OLED TV)

Precautions to Protect the Screen from Damage

Image retention

OLED TV's are susceptible to image retention (burn-in) due to the characteristics of the materials used. Image retention may occur if images are displayed in the same location on the screen repeatedly or over extended periods of time. This is not a malfunction of the TV. Avoid displaying images that may cause image retention.

The following are examples of images that may cause image retention:

- Content with black bars either on the top and bottom and/or the left and right sides of the screen. (for example, Letterboxed, 4:3 screen, Standard definition)
- Static images such as photos.
- Video games that might have static content in some part of the screen.
- On-screen menus, programme guides, channel logos etc.
- Static content from applications.
- On-screen tickers, such as those used for news and headlines.

To reduce the risk of image retention:

- Sony recommends that you turn off the TV normally by pressing the power button on the remote control or the TV.
- Fill the screen by changing [Wide mode] to eliminate the black bars. Select [Wide mode] other than [Normal].
- Turn off the OSD (On Screen Display) by pressing the /? (Info/Text reveal) button, and turn off the menus from connected equipment. For details, refer to the instruction manuals for the connected equipment.
- Avoid displaying static images with bright colours (including white), clocks or logos on any portion of the screen.
- Set the picture settings based on the ambient conditions. The Standard Picture is recommended for home use and when viewing content that often displays the station logos, etc.

The TV has following features to help reduce/prevent image retention.

Panel refresh

A panel refresh will adjust the panel uniformity. Panel refresh can be performed and should only be used when image retention is very noticeable.

Caution:

- The Panel refresh function may affect the panel. Do not perform Panel refresh more than once a year as it may affect the usable life of the panel.
- Panel refresh takes about one hour to complete.
- A white line may be displayed on the screen during the Panel refresh, this is not a malfunction of the TV.
- Panel refresh will only work when the room temperature is between 10 °C and 40 °C.

Pixel shift

Automatically moves the image on the screen to prevent image retention.

Other feature

The screen brightness is automatically reduced when displaying still images, clocks, bright colours or logos etc.

Using TV as Centre Speaker

Note

- Before connecting cables, disconnect the mains lead of both TV and AV receiver.

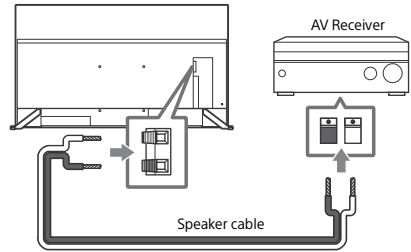

Using TV as Part of Audio System

Note

- Before connecting cables, disconnect the mains lead of both TV and AV receiver.
- Refer to the instruction manual of the Audio system with S-CENTER OUT terminal for detail.

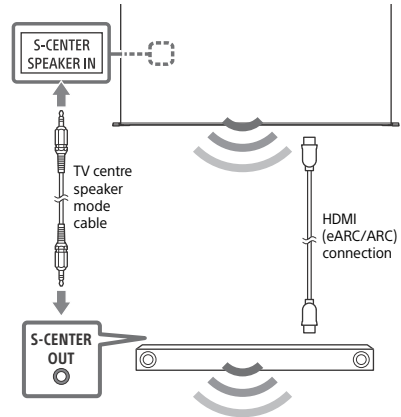

Remote Control and TV

The remote control shape, layout, availability and function of remote control buttons may vary depending on your region/country/TV model/TV settings.

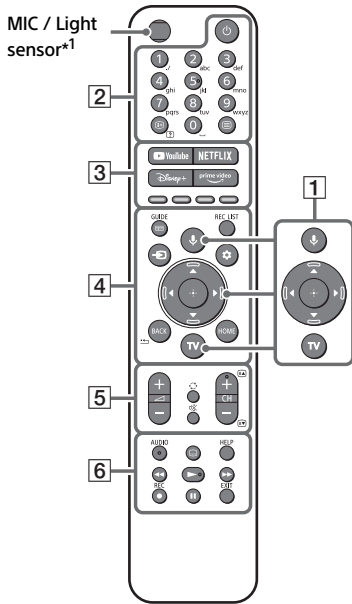

- 1** **🔊 (Microphone) / ***: **(Google Assistant):** Use Google Assistant*^{2,3} or voice search*³. For hints on how to control your TV, press the microphone button on the remote control and say "voice hints".*²

▲/▼/◀/▶/⊕: On screen menu navigation and selection.

TV: Display TV channel list or switch to input.
- 2** **⏻ (Power)**

Number buttons

ℹ️/? (Info/Text reveal): Display information.

☰ (Text): Display text information.
- 3** **YouTube™ / NETFLIX / Disney+ / Prime Video / Colour buttons**
- 4** **GUIDE/☰**: Display the digital programme guide of TV or TV box*⁴.

REC LIST: Display the Rec list of USB HDD*⁵/DVR*⁴.

↵ (Input select): Display and select the input source, etc.

⚙️ (Quick settings): Display Quick Settings.

BACK/⬅️

HOME

- 5** **↕ +/- (Volume)**

⏩ (Jump)

🔇 (Mute)*⁶

CH +/-/⏪/⏩: Select the channel, or next (⏪) / previous (⏩) page.
- 6** **AUDIO**: Select the sound of multilingual source or dual sound (depend on programme source).

⋮ (Subtitle setting)

HELP: Display the Help menu.

◀◀/▶▶/⏸/⏹

● REC: Record the currently viewed programme on USB HDD*⁵/DVR*⁴.

EXIT

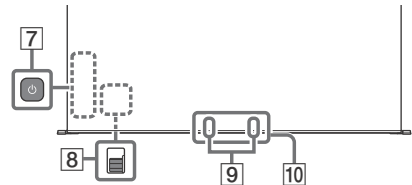

- 7** **⏻ (Power)**

(It can be found by removing the side cover (XR-83A9xJ only).)
- 8** **BUILT-IN MIC SWITCH**: Turn on/off the built-in MIC. (It can be found by removing the side cover)
- 9** **Built-in MIC*^{2,3,7}**: To enable the built-in MIC, press the microphone button on the remote control and follow the on-screen instructions.
- 10** **Remote Control sensor / Ambient light sensor / LED**

- *1 The remote control backlight will illuminate when the light sensor detects the ambient light is low. Automatic illumination of the backlight can be turned off.
- *2 Only on limited region/country/TV model/language.
- *3 Google Assistant or voice search requires an Internet connection.
- *4 [TV box setup] setting is required.
- *5 Not available for Italy.
- *6 Accessibility shortcut is available by pressing and holding m^* (Mute).
- *7 Power consumption will increase when the built-in MIC is enabled as it is always listening.

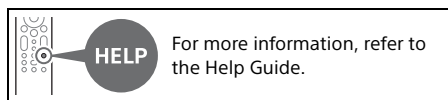

Installing the TV to the Wall

Using the optional Wall-Mount Bracket (SU-WL850 or SU-WL450)* (not supplied)

To Customers:

For product protection and safety reasons, Sony strongly recommends that installation of your TV be performed by Sony dealers or licensed contractors. Do not attempt to install it yourself.

To Sony Dealers and Contractors:

Provide full attention to safety during the installation, periodic maintenance and examination of this product.

Wall-Mount Bracket Installation Information

For instructions on Wall-Mount Bracket installation, see the Installation Information (Wall-Mount Bracket) on the product page for your TV model.

<https://www.sony.eu/support>

- Follow the instruction guide provided with the Wall-Mount Bracket for your model. Sufficient expertise is required in installing this TV, especially to determine the strength of the wall for withstanding the TV's weight.
- Sony is not liable for any damage or injury caused by mishandling or improper installation.
- Only qualified service personnel should carry out wall-mount installations.
- For safety reasons, it is strongly recommended that you use Sony accessories, including:
 - Wall-Mount Bracket SU-WL850 (XR-65A9xJ / 55A9xJ only)
 - Wall-Mount Bracket SU-WL450

- Be sure to use the screws supplied with the TV when attaching the Wall-Mount Bracket to the TV set (SU-WL850 only). Be sure to use the screws supplied with the Wall-Mount Bracket when attaching the Wall-Mount Bracket to the TV set (except SU-WL850). The supplied screws are designed as indicated by illustration when measured from the attaching surface of the Wall-Mount Bracket. The diameter and length of the screws differ depending on the Wall-Mount Bracket model. Use of screws other than those supplied may result in internal damage to the TV set or cause it to fall, etc.

XR-83A9xJ

10 mm – 14 mm

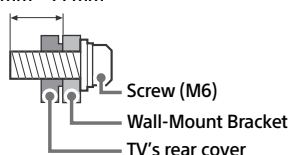

XR-65A9xJ / 55A9xJ

9 mm – 13 mm

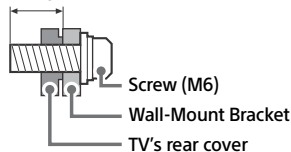

- Be sure to store the unused screws and Table-Top Stand in a safe place until you are ready to attach the Table-Top Stand. Keep the screws away from small children.

* Only on limited region/country/TV model.

Troubleshooting

General troubleshooting for issues like: black screen, no sound, frozen picture, TV does not respond, or network is lost, do the following steps.

- 1 Restart your TV by pressing the power button on the remote control for about five seconds. The TV will restart. If the TV does not recover, try unplugging the mains lead then press the power button on the TV and release it. Wait for two minutes, and plug in the mains lead. Or, press the power button on the TV for about 40 seconds until the TV turns off.
- 2 Refer to the Help menu by pressing **HELP** on the remote control.
- 3 Connect your TV to the Internet and perform a software update. Sony recommends you to keep your TV software updated. Software updates provide new features and performance improvements.
- 4 Visit Sony support website (information provided at the end of this manual).

When you plug in the TV, the TV may not be able to turn on for a while even if you press the power button on the remote control or the TV.

It takes time to initialize the system. Wait for about one minute, then operate it again.

The remote control does not function.

- Replace the batteries.

The parental lock password has been forgotten.

- Enter 9999 for the PIN and enter the new PIN.

The screen becomes darker while watching TV.

- If the whole image or part of the image remains still, the screen brightness will be gradually reduced to prevent image retention. This is not a malfunction of the TV.

You are concerned about image retention.

If the same image is displayed repeatedly or for long periods of time, image retention may occur. To reduce image retention, we recommend that you turn off the TV normally by pressing the power button on the remote control or the TV.

Note

- Perform Panel refresh only when image retention is particularly noticeable. Avoid performing Panel refresh more than once a year because it may affect the usable life of the panel.
- Images that include clocks, logos and bright colours (including white) easily cause image retention. Avoid displaying these types of images for long periods of time, otherwise image retention may occur.

A white line appears on the screen.

- The Panel refresh has been performed. A white line may be displayed on the screen during the Panel refresh. This is not a malfunction of the TV. Panel refresh starts after the TV is turned off and takes about one hour to complete.

The message [Panel refresh did not finish...] is displayed.

When i) the TV is turned on, ii) the mains lead is unplugged, or iii) the room temperature falls outside of the range between 10 °C and 40 °C during the Panel refresh, the Panel refresh is not completed. Please avoid the above three conditions during the Panel refresh.

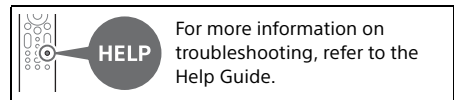

Specifications

System

Panel system: OLED (Organic Light Emitting Diode) Panel

TV system: Depend on your country/area selection/TV model

Analogue: B/G, D/K, I

Digital: DVB-T/DVB-C/DVB-T2

Satellite: DVB-S/DVB-S2

Colour system: PAL/SECAM/NTSC3.58 (Video only)/NTSC4.43 (Video only)

Channel coverage: Depend on your country/area selection/TV model

Analogue: UHF/VHF/Cable

Digital: UHF/VHF/Cable

Satellite: IF Frequency 950-2150 MHz

Sound output: 20 W + 20 W + 10 W + 10 W

Wireless technology

Protocol IEEE 802.11a/b/g/n/ac

Bluetooth® Version 4.2

Frequency band(s)

Frequency range	Output power
Wireless LAN (TV)	
2400-2483.5 MHz	< 20.0 dBm
5150-5250 MHz	< 23.0 dBm
5250-5350 MHz	< 20.0 dBm
5470-5725 MHz	< 20.0 dBm
5725-5850 MHz	< 13.9 dBm
Bluetooth® (TV)	
2400-2483.5 MHz	< 10.0 dBm
Bluetooth® (Remote control)	
2400-2483.5 MHz	< 10.0 dBm

Input/Output jacks

Antenna (aerial)/cable

75 ohm external terminal for VHF/UHF

Satellite antenna

Female F Type Connector, 75 ohm.

DiSEqC 1.0, LNB 13 V/18 V & 22 kHz tone, Single Cable Distribution EN50494.

AV IN / S-CENTER SPEAKER IN

Video/Audio input (mini jack)

S-centre speaker input (mini jack)

HDMI IN 1/2/3/4 (HDCP 2.3-compatible)

Video:

4096 × 2160p (50, 60 Hz)^{*1*2}, 4096 × 2160p (24 Hz)^{*1}, 3840 × 2160p (50, 60 Hz)^{*2}, 3840 × 2160p (24, 25, 30 Hz), 1080p (30, 50, 60, 100, 120 Hz), 1080/24p, 1080i (50, 60 Hz), 720p (30, 50, 60 Hz), 720/24p, 576p, 480p, PC Formats^{*3}
3840 × 2160p (100, 120 Hz)^{*2*4}

Audio:

In eARC (Enhanced Audio Return Channel) mode

Refer to the online Help Guide for details.

Except eARC mode

5.1 channel linear PCM: 32/44.1/48/88.2/96/176.4/192 kHz 16/20/24 bits, Dolby Audio, Dolby Atmos, DTS

eARC/ARC (Enhanced Audio Return Channel/Audio Return Channel) (HDMI IN 3 only)^{*5}

In eARC mode

Refer to the online Help Guide for details.

In ARC mode

Two channel linear PCM: 48 kHz 16 bits, Dolby Audio, Dolby Atmos, DTS

DIGITAL AUDIO OUT (OPTICAL)

Digital optical jack (Two channel linear PCM: 48 kHz 16 bits, Dolby Audio, DTS)

(Stereo mini jack)

Headphone

1, 2, 3 (HDD REC)^{*6}

USB device port (3 USB HDD device for REC feature)

USB port 1 and 2 support High Speed USB (USB 2.0)

USB port 3 supports Super Speed USB (USB 3.1 Gen 1)



CAM (Conditional Access Module) slot



10BASE-T/100BASE-TX connector (Depending on the operating environment of the network, connection speed may differ. The communication rate and quality are not guaranteed.)

CENTER SPEAKER IN

Centre speaker input terminal

Power, Product Fiche and others

Power requirements

220 V – 240 V AC, 50 Hz

Energy Efficiency Class^{*7}

XR-65A9xJ: A

XR-55A9xJ: B

Screen size (measured diagonally) (Approx.)

XR-83A9xJ: 209.6 cm / 83 inches

XR-65A9xJ: 163.9 cm / 65 inches

XR-55A9xJ: 138.8 cm / 55 inches

Power consumption^{*7}

In [Standard] mode

XR-65A9xJ: 151 W

XR-55A9xJ: 121 W

Annual energy consumption^{*7*8}

XR-65A9xJ: 209 kWh per year

XR-55A9xJ: 168 kWh per year

Standby power consumption^{*7*9*10}

XR-65A9xJ / 55A9xJ: 0.50 W (26 W in software/EPG update mode)

Display resolution (horizontal × vertical) (pixels)

3840 × 2160

Output rating

500 mA (for USB 1/2), 900 mA (for USB 3)

Dimensions (Approx.) (w × h × d) (cm)

with Table-Top Stand

Standard position:

XR-83A9xj: 188.0 × 107.2 × 42.8

XR-65A9xj: 150.2 × 83.4 × 31.7

XR-55A9xj: 128.2 × 70.9 × 31.7

Narrow position:

XR-83A9xj: 185.0 × 109.9 × 42.8

Soundbar position:

XR-83A9xj: 188.0 × 113.7 × 42.8

XR-65A9xj: 144.4 × 90.2 × 31.7

XR-55A9xj: 122.3 × 77.6 × 31.7

without Table-Top Stand

XR-83A9xj: 185.0 × 106.7 × 5.3

XR-65A9xj: 144.4 × 83.3 × 4.1

XR-55A9xj: 122.3 × 70.9 × 4.1

Stand width (Approx.) (cm)

Standard position:

XR-83A9xj: 188.0

XR-65A9xj: 150.2

XR-55A9xj: 128.2

Narrow position:

XR-83A9xj: 70.0

Soundbar position:

XR-83A9xj: 188.0

XR-65A9xj: 136.5

XR-55A9xj: 115.0

Mass (Approx.) (kg)

with Table-Top Stand

XR-83A9xj: 43.5

XR-65A9xj: 24.6

XR-55A9xj: 20.3

without Table-Top Stand

XR-83A9xj: 42

XR-65A9xj: 22.5

XR-55A9xj: 18.6

Others

Optional accessories

Wall-Mount Bracket: SU-WL850 (XR-65A9xj / 55A9xj only)

Wall-Mount Bracket: SU-WL450

Operating temperature: 0 °C – 40 °C

Operating humidity: 10 % – 80 % RH

(non-condensing)

*1 When 4096 × 2160p is input and [Wide mode] is set to [Normal], the resolution is displayed as 3840 × 2160p. To display 4096 × 2160p, set [Wide mode] setting to [Full 1] or [Full 2].

*2 Refer to the on screen menu to set [HDMI signal format].

*3 Refer to the online Help Guide for details.

*4 HDMI IN 3 & 4 only. Use the Ultra High Speed HDMI Cable to connect.

*5 Connect your audio system to the HDMI IN 3 to route TV audio to your audio system.

*6 Function not available in Italy.

*7 This information is for EU and other countries whose relevant regulation is based on EU energy labelling regulation.

*8 Energy consumption in kWh per year, based on the power consumption of the television operating 4 hours per day for 365 days. The actual energy consumption will depend on how the television is used.

*9 Specified standby power is reached after the TV finishes necessary internal processes.

*10 Standby power consumption will increase when your TV is connected to the network.

Note

- Optional accessories availability depends on countries/region/TV model/stock.
- Design and specifications are subject to change without notice.
- Subscriptions for services and applications may be required and additional terms, conditions and/or charges may apply when using Google Assistant.
- Product fiche in this manual is for COMMISSION DELEGATED REGULATION (EU) 1062/2010. Refer to its website for (EU) 2019/2013 information.

Notes on Digital TV function

- Digital TV (DVB terrestrial, satellite and cable), interactive services and network functions may not be available in all countries or areas. Some functions might not be enabled or might not operate correctly with some providers and network environments. Some TV service providers may charge a fee for their services.
- This TV supports digital broadcasting using MPEG-2, H.264/MPEG-4 AVC and H.265/HEVC codecs, but compatibility with all operator/service signals, which may change over time, cannot be guaranteed.

Trademark Information

- The terms HDMI, HDMI High-Definition Multimedia Interface, and the HDMI Logo are trademarks or registered trademarks of HDMI Licensing Administrator, Inc.
- Dolby, Dolby Vision, Dolby Atmos, Dolby Audio, and the double-D symbol are trademarks of Dolby Laboratories Licensing Corporation. Manufactured under license from Dolby Laboratories. Confidential unpublished works. Copyright © 1992-2020 Dolby Laboratories. All rights reserved.
- Gracenote, the Gracenote logo and logotype, "Powered by Gracenote" logo are either registered trademarks or trademarks of Gracenote, Inc. in the United States and/or other countries.

- Google TV and related logos are trademarks of Google LLC.
- For DTS patents, see <http://patents.dts.com>. Manufactured under license from DTS, Inc. DTS, Digital Surround, and the DTS logo are registered trademarks or trademarks of DTS, Inc. in the United States and other countries. © 2020 DTS, Inc. ALL RIGHTS RESERVED.
- Netflix is a registered trademark of Netflix, Inc.
- DiSEqC™ is a trademark of EUTELSAT. This TV supports DiSEqC 1.0. This TV is not intended for controlling motorized antennas.
- TUXERA is a registered trademark of Tuxera Inc. in the US and other countries.
- All other trademarks are the property of their respective owners.

**Product registration number
(COMMISSION DELEGATED
REGULATION (EU) 2019/2013)**

XR-83A90J (403711), XR-65A90J (403708),
XR-55A90J (403707).